

Braun Corporation FMVSS No. 403 Quick Reference Installation Sheet 32553

Braun Corporation FMVSS No. 403 Quick Reference Installation Sheet 32253

“DOT — Public Use Lift”

NHTSA Vehicle Physical Requirements

Vehicle Requirements:

All vehicles with a GVW over 6000 lbs. and with unmodified OEM framersails.

Alternative floor structures are allowed providing the installed lift system passes all FMVSS 403 requirements.

Mounting Bracket Requirements:

A maximum distance of 16" from the outermost mounting bracket to the end of the cassette.

All mounting brackets must be used. At least four of the brackets must be connected to the framersails.

“DOT - Public Use Lift” verifies this platform lift meets the “public use lift” requirements of FMVSS No. 403. This lift may be installed on all vehicles appropriate for the size and weight of the lift, but must be installed on buses, school buses, and multi-purpose passenger vehicles other than motor homes with a gross vehicle weight rating (GVWR) that exceeds 4,536 kg (10,000 lb).

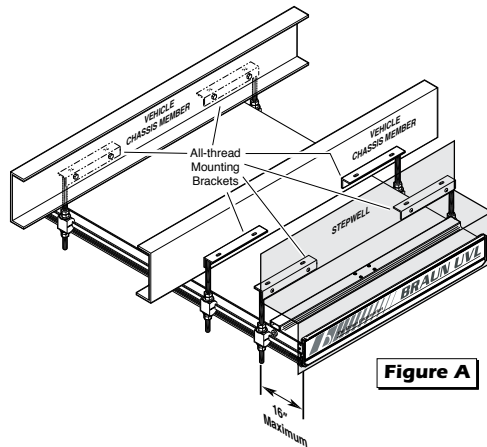

Figure A

Door Opening Dimensions

Vehicle lift access door opening must meet specified dimensions.

	604	855
A Minimum Clear Door Opening Height	NA	NA
B Clear Door Opening Width	40-1/2"	43-1/2"
C Maximum Floor-to-Ground	34"	50"

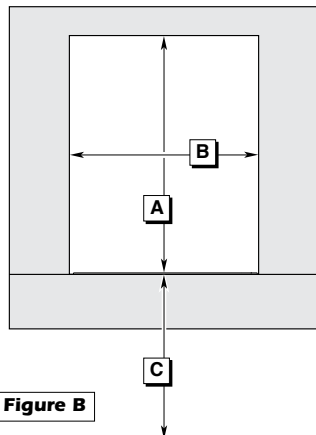

Figure B

1 Locate Lift Mounting Brackets

Locate All-Thread Mounting Brackets

1. Open both doors to 90°.
2. Locate center of door opening (between doors). Mark the center point.
3. Transfer center point to the vehicle frame. Using a front-to-rear framing member as a guide, transfer the center point across chassis to opposite side front-to-rear framing member (must be 90° to door opening). Lift mounting bracket positions are based on this center line.
4. **604 Series Only:** Measure 20-7/8" to left and right of the center line to achieve the 41-3/4" center-to-center spacing of all-thread mounting studs.
5. **855 Series Only:** Measure 22-3/8" to left and right of the center line to achieve the 44-3/4" center-to-center spacing of all-thread mounting studs.
5. Clamp the mounting brackets securely in place (all-thread studs must be vertical).

Engage Platform Manual Release System: The lift cable-activated platform manual release is disengaged during shipment to prevent potential drive chain stretch. Handle the lift with care. **Engage manual release before attempting to install** (raise, tilt or move) the lift.

⚠ WARNING

Engage manual release before attempting to install (raise, tilt or move) lift. Failure to do so may result in serious bodily injury and/or property damage.

Figure C

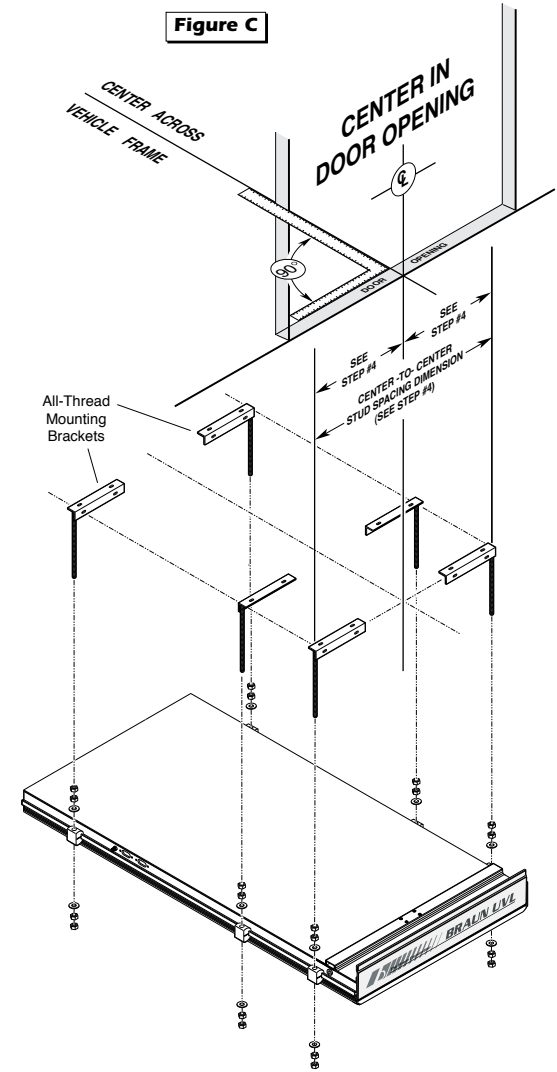

2 Secure Lift

Attach Mounting Brackets to Vehicle Frame

Mounting bolts must be routed horizontally through the vertical face of the "L" brackets and framing members as shown in Figures D, E and F.

Eight 3/8-16 x 1-1/2" hex bolts are supplied for bolting the all-thread mounting brackets to the frame (two per bracket). Oval slotted mounting holes are provided in the mounting brackets to allow adjustment. **Carefully** drill 25/64" (.390") diameter mounting holes at the center of the oval mounting slots.

Channel Frame Applications: Secure mounting bolts as specified in Figure D.

Box Frame Spacers: Position tubing spacers as shown at right to prevent collapsing the box frame. **Carefully** drill a 25/64" (.390") diameter mounting hole through one side of the box frame. Drill a 5/8" (.625") diameter hole through the opposite side of box frame to allow installation of spacer. Cut spacer tubing to length (equal to thickness of box frame).

Note: A longer 3/8-16 bolt will be required for box frame applications. Secure mounting bolts as specified in Figures E and F.

All fasteners **must** meet FMVSS 571.403 Section 6.3.

Shipping Block Removal: Wood blocks are placed in the lift housing to prevent lift damage during shipment. **Remove shipping blocks** from platform and carriage **before running (activating) lift.** Refer to **Shipping Block Removal** Instruction 28942.

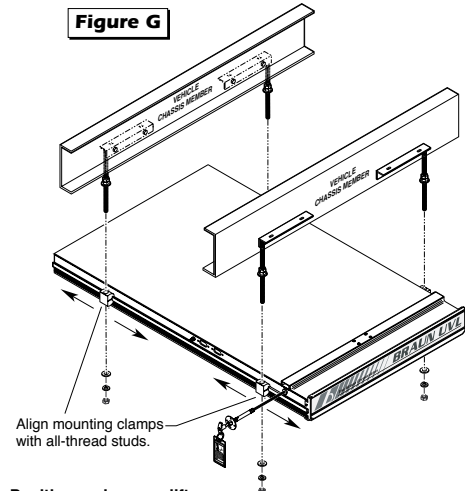
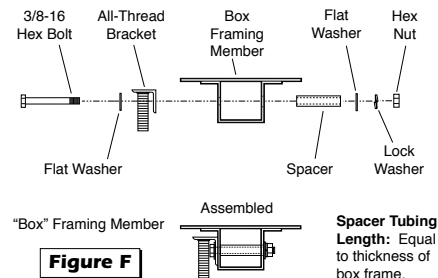
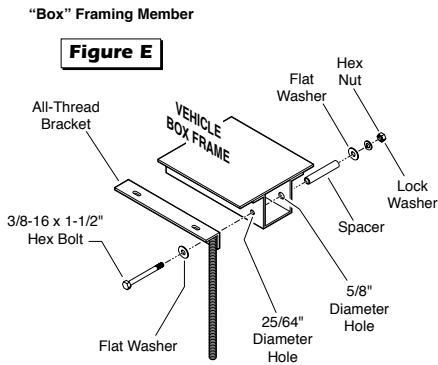
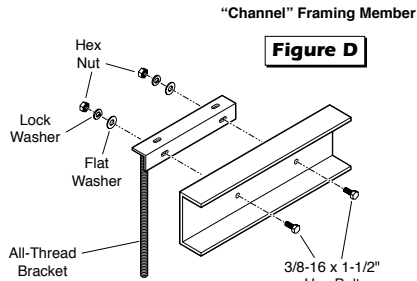

Position and secure lift.

Thread two 3/4" hex jam nuts fully onto each mounting bracket all-thread stud. Place one large diameter flat washer onto each all-thread stud (use tape to hold in place). See Figures G and H.

Carefully position lift under vehicle (aligned with mounting brackets). Position (slide) the four lift mounting clamps along the sides of the lift housing until aligned with mounting bracket all-thread studs. See Figure G.

Height Adjustment

The lift housing **must** be aligned with vehicle chassis. Adjust the 3/4" hex jam nuts on the all-thread mounting studs at all 4 corners of the lift until dimensions A, B, C and D are equal (within 1/16"). See Figure J.

In-Out Positioning
Position the lift to achieve a 2" overlap between the deployed inboard barrier and the vehicle floor.

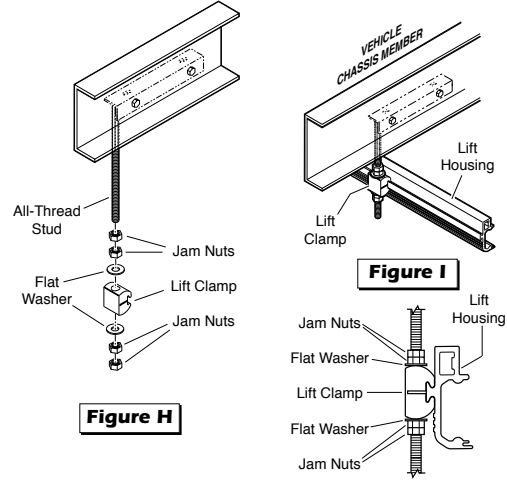

Note: The two outboard mounting brackets **should be positioned a maximum of 16" from the end of the cassette.** See Figure A.

Carefully raise lift into position as high as possible (height adjustment outlined below). Place one large diameter flat washer onto each mounting bracket all-thread stud. Thread two 3/4" hex jam nuts fully onto each all-thread stud (up against lift mounting clamp).

Shift lift and mounting brackets left-to-right as needed (lift must be centered in door opening). **Tighten the 3/8" bolts** securing mounting brackets to the frame. **Torque Specifications:** 25 to 30 foot pounds.

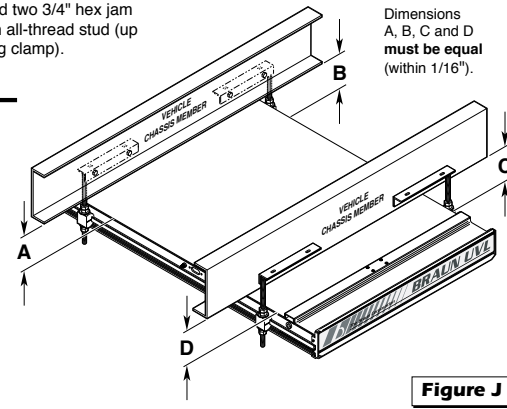

Dimensions A, B, C and D must be equal (within 1/16").

3 Electrical, Hydraulic and Interlock

Pump Module Mounting

Mount reinforcement "L" bracket to pump mounting bracket as shown in Figure K. Secure pump mounting bracket to floor using four 5/16" lag bolts.

Check under vehicle for obstructions before drilling, cutting holes or installing floor mounting hardware.

Note: Locate and drill pump module mounting holes, floor grommet 3" diameter hole and manual release 7/8" diameter hole **before** mounting pump.

Cable-activated Manual Release: The T-handle must be mounted inside the vehicle. The cable must operate freely (no kinks or bends). Warning tag 81823 must remain attached to the handle. Remove handle for installation.

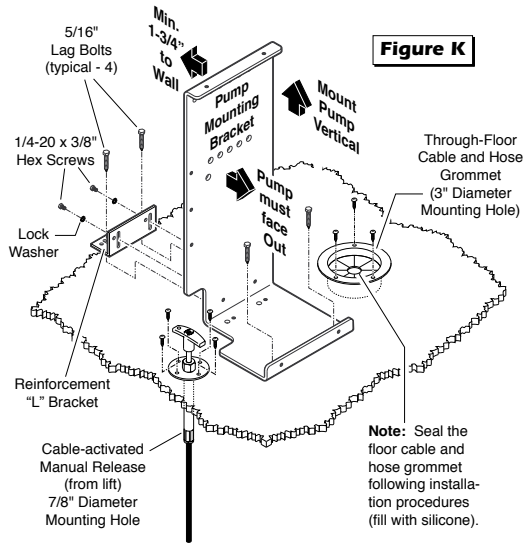

Figure K

Note: Seal the floor cable and hose grommet following installation procedures (fill with silicone).

Note: All wiring harness connections **must be inside the vehicle.**

Vehicle Battery Ground Cable:

A ground cable (minimum 2 gauge) must be connected from vehicle battery negative post to the same vehicle framing member the pump ground cable is attached to.

Ground Cable Corrosion: When mounting ground cables, remove undercoating, dirt, rust, etc. from framing member around mounting holes. Apply protective coating to mounting holes to prevent corrosion. **Failure to do so will void warranty of certain electrical components.**

Pump Ground Cable:

One ground cable is pump mounted. Route this ground cable through the floor grommet and connect to a vehicle framing member (see Figure L).

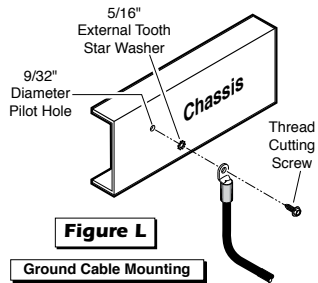

Figure L

Hydraulics:

Remove the plug from 1/4" diameter clear vent tube. See Figure N.

Route hydraulic hose assembly through floor grommet to quick-disconnect fitting at lift. Connect hose.

Circuit Sentry:

Install Circuit Sentry as shown in Figure M. Attach power cable and lead cable as detailed.

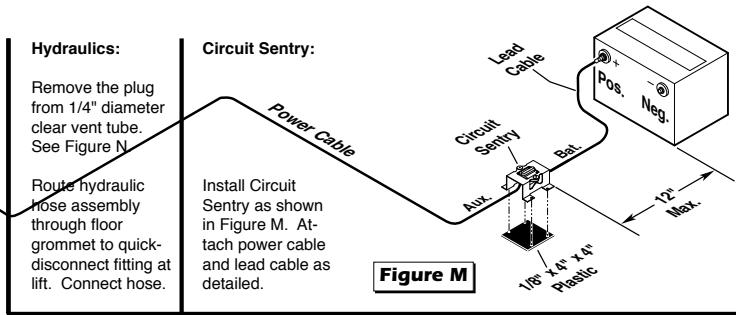

Figure M

Jumper Wire

Install black jumper wire last. Install the black jumper wire in pump Terminal Strip terminals 6 and 9 **after** all other electrical connections have been made (see Panel 4). The jumper wire supplies power to the circuit board. Check floor level and bridge plate adjustments as detailed in Panel 4 **before operating lift with electric pump.**

Note: Remove plug from vent tube.

Connect red positive (+) power cable here (from Circuit Sentry).

Figure N

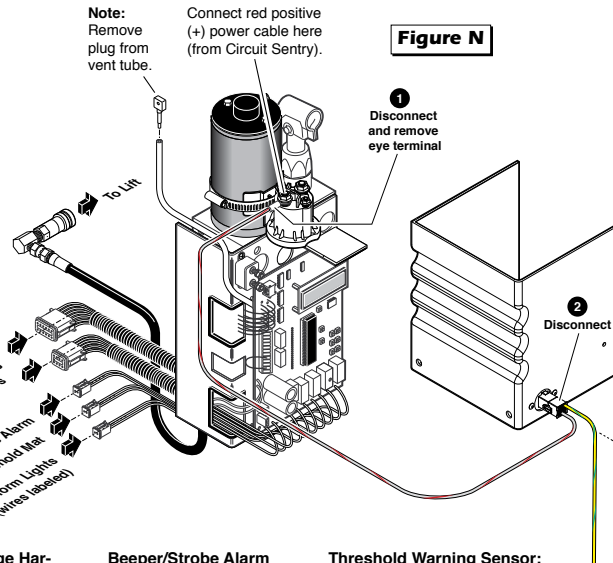

Vehicle and Lift Interlocks

The pump module is equipped with a lift interface 9-circuit connector (female socket). A mating 9-circuit connector (male plug) is supplied.

To meet **minimum** NHTSA requirements, connect to vehicle interlock harness as outlined in Figure N (Steps 1-4).

Optional Interlock Kits

Universal Interlock Kit 30940K is available for easy interface with vehicle OEM electronic signals.

Instrument Panel Display Kit 30938K provides an LED Panel Display that interfaces with Braun Universal Interlock Kit 30940K.

Note: Detailed installation instructions are supplied with interlock kits.

Housing/Carriage Harnesses:

Route two main wiring harnesses from lift through floor grommet to pump module. Connect to mating harnesses at pump.

Beeper/Strobe Alarm and Platform Lights:

Connect harnesses to mating harnesses at pump (labeled). Detailed installation instructions supplied with kits.

Threshold Warning Sensor:

Connect harness to mating harness at pump module (labeled). **Mat must be installed on a flat rigid surface.** Inboard edge of mat must be **minimum 18"** from edge of finished floor or stepwell.

4 Door Operators/Switch, Terminal Strip and Floor Level Adjustment

Terminal Strip

The pump-mounted terminal strip provides additional inputs and outputs that can be used for optional door operators, beepers, interlocks, etc. - as well as the door safety switch. The black jumper wire must be installed in terminals 6 and 9 to supply power to the circuit board.

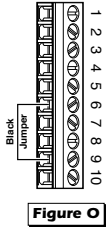

Figure O

Power Door Operators

Install optional power door operators as detailed in the instructions supplied with door operator kit.

Route the wires to the pump module and connect to the terminal strip as shown in Figure P.

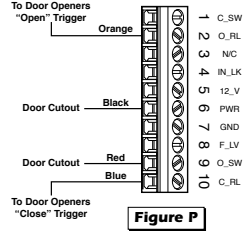

Figure P

Floor Level and Bridge Plate Adjustments

Achieving proper floor level positioning of the platform and bridge plate requires a combination of Floor Level switch adjustment and bridge plate adjustment. Both are factory set but must be inspected during installation procedures (will vary per vehicle application).

Ensure the lift is positioned and secured as specified above (panels 1 and 2). **Adjust the Floor Level switch first** (detailed below). Then, adjust the bridge plate as detailed in Bridge Plate Adjustment Instructions 31756 (adjust only if necessary). The bridge plate must rest properly on the vehicle floor for wheelchair entry and exit.

Floor Level Switch

The Floor Level switch stops upward travel of the platform during the Up function (activated by the torque tube-mounted Floor Level cam). Position the lift platform 1" above floor level **using the manual operation system** (detailed on opposite side of this sheet). Loosen the clamp securing the torque tube-mounted Floor Level cam. Rotate the cam until the Floor Level switch is activated (cam depresses switch).

Note: Check the floor level position of the platform and the bridge plate after powering the pump. Hydraulic pressure may affect platform height slightly. Fine tuning adjustment (tweak-

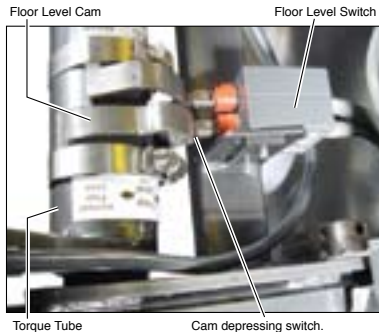

5 FMVSS 403/404 Certification Checklist

Visual and Audible Threshold Warning

DOT – Public Use Lift

Public use vehicle manufacturers are responsible for complying with the lift lighting requirements in Federal Motor Vehicle Safety Standard No. 404, Platform Lift Installation in Motor Vehicles (49 CFR 571.404).

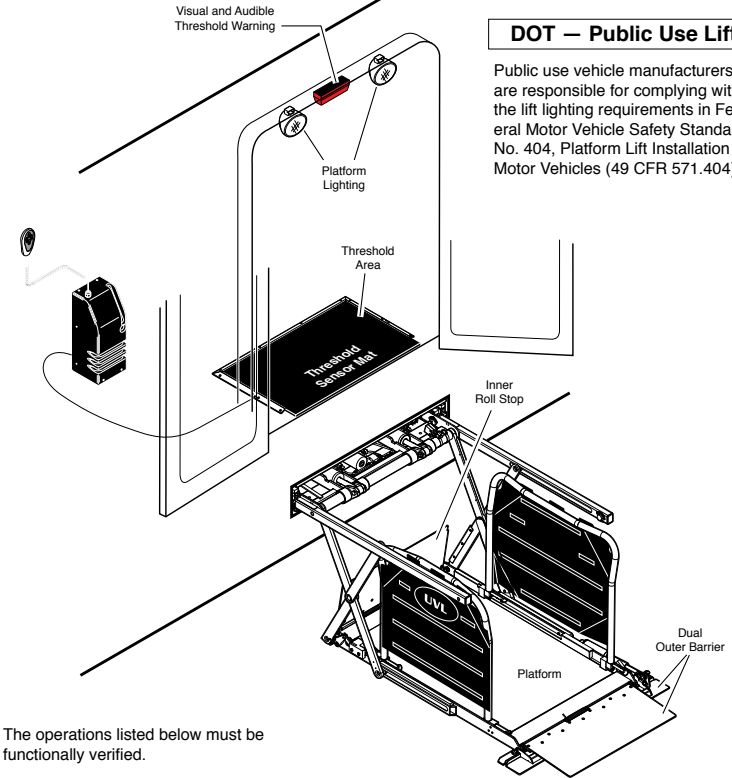

The operations listed below must be functionally verified.

- Vehicle movement is prevented unless the lift door is closed, ensuring the lift is stowed.
- Lift operation shall be prevented unless the vehicle is stopped and vehicle movement is prevented.
- The platform will not fold/stow if occupied.
- The outer barrier will not raise if occupied.
- The inner rollstop will not raise if occupied.
- Lowering the platform beyond the inner rollstop locking position is allowed only when the inner rollstop is locked in position.
- An audible and visual warning will activate if the threshold area is occupied when the platform is at least one inch below floor level.
- Lift platform movement shall be interrupted unless the outer barrier is raised.

Lift Operating Instructions

Note: The instructions outlined here are applicable for "Public-Use" NUVL lift models equipped with dual

folding handrails and a dual outer barrier system.

Before lift operation, park the vehicle on a level surface, away from vehicular traffic. Place the vehicle transmission in "Park" and engage the parking brake. Open manual doors fully, being certain the doors are secured in the fully open position.

It is the responsibility of the lift operator (attendant) to properly open, secure and close the vehicle lift doors, to activate any auxiliary interlock (if equipped), to load and unload the wheelchair passenger (or standee) on and off the lift platform, and to properly activate all lift functions.

In event of power or equipment failure, refer to the Manual Operating Instructions section.

Handrails and Dual Outer Barrier:

The folding handrails and tall outer barrier are manually operated. The spring-loaded outer barrier (tall barrier) and the handrails rest on the platform when the lift is not in use. The outer barrier **must** be raised to the vertical position and the handrails **must** be lifted to the vertical position whenever a passenger is on the platform.

The tall outer barrier and the handrails **must** be folded down to the platform (horizontal) position **before stowing** the lift. The handrails fold down onto the outer barrier to secure the barrier in the horizontal position.

Each handrail is secured with two detent pins (one pin at the base of each vertical support tube). The detent pins must be removed before the handrails can be folded or unfolded and the **detent pins must be reinserted after folding or unfolding** the handrails.

⚠WARNING

Whenever a passenger is on the platform, the:

- Passenger must be positioned fully inside yellow boundaries
- Wheelchair brakes must be locked
- Inner roll stop and outer barrier must be up.

Failure to do so may result in serious bodily injury and/or property damage.

Hand-held Pendant Control

The ergonomic hand-held attendant's pendant control is equipped with four push button switches, (UP, STOW, DOWN and DOOR).

A graphic appears on each button that represents the corresponding lift function. When there is power to the lift, the lift function labels illuminate to identify the function(s). The STOW label features a red LED to enhance awareness.

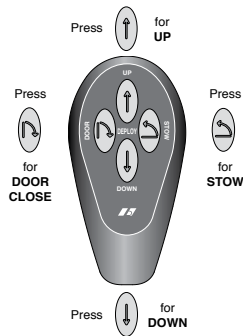

Control Switch Functions:

UP: From the stowed position, pressing the UP switch deploys (extends) the platform fully. Release the UP switch once the platform has extended fully in order to deploy the outer barrier and handrails. The platform will continue to raise to floor level if the UP switch is not released and handrail procedures may be more difficult (floor level height varies per vehicle). Pull the handrail detent pins and lift the handrails to the vertical position. Reinsert the detent pins after the handrails are raised. Lift the outer barrier to the vertical position. Press the UP switch until the platform stops (raises to floor level), and the inner roll stop unfolds to floor level.

From ground level, the UP function will first automatically raise (rotate) the outer barriers to the upright (vertical) position. The platform then raises to floor level position. **Note:** The lift will not raise if the outer barrier is not in the UP position (built-in safety feature).

DOWN: The DOWN function lowers the platform to ground level and then unfolds the outer barriers to the ramp (horizontal) position. From the stowed position, the lift will extend fully and then lower.

STOW: The STOW function raises or lowers the platform to stow level and then moves the platform inward (retracts) to the stow position. **Handrails and Outer Barrier:** The tall outer barrier and the handrails **must** be folded down to the platform (horizontal) position **before stowing** (retracting) the platform. The handrail detent pins **must** be reinserted **before stowing** the platform also. **Note:** The lift will not stow with weight on the platform (built-in safety feature).

DOOR CLOSE: This function is not applicable for "Public-Use" NUVL lift models (manual door system and attendant operated lift).

Note: If any of these functions do not occur as described, discontinue lift use immediately and contact your sales representative or call The Braun Corporation at 1-800-THE LIFT®. One of our national Product Support representatives will direct you to an authorized service repairman who will inspect your lift.

Lift Operating Instructions

OPEN DOOR(S) AND SECURE

Manually open door(s) **fully** and secure.

TO DEPLOY PLATFORM:

1. **Stand clear** and press the UP switch until the platform extends **fully**. Release switch.
2. Pull handrail detent pins, lift handrails up to vertical position and reinsert detent pins.
3. Lift outer barrier to vertical position.
4. Press the UP switch until the platform stops (raises to **floor level**) and inner roll stop unfolds to floor level. Release switch.

TO UNLOAD PASSENGER:

1. **Read Note below!** Load passenger onto platform and **lock** wheelchair brakes.
- Note:** Passenger **must** be positioned **fully inside yellow boundaries** and outer barrier **must** be UP.
2. Press DOWN switch until the **entire** platform reaches ground level and the outer barrier **unfolds fully** (ramp position). Release switch.
 3. Unlock wheelchair brakes and unload passenger from platform.

Note: Outer barrier **must** be **fully unfolded** (ramp position) until the entire wheelchair (or standee) has crossed the outer barrier.

TO LOAD PASSENGER:

1. **Read Notes below!** Load passenger onto platform and **lock** wheelchair brakes.

Note: Outer barrier **must** be **fully unfolded** (ramp position) until the entire wheelchair (or standee) has crossed the outer barrier.

Note: Passenger **must** be positioned **fully inside yellow boundaries**.

2. Press UP switch to fold outer barrier UP **fully** (vertical), raise the platform to **floor level** and unfold inner roll stop to **floor level**. Release switch.
3. Unlock wheelchair brakes and unload passenger from platform.

TO STOW PLATFORM:

1. Fold outer barrier down to platform (horizontal) position.
2. Pull handrail detent pins, fold handrails down to platform (horizontal) position and reinsert detent pins.
3. Press STOW switch until platform stops (retracts **fully**). Release switch.

CLOSE DOOR(S)

Manually close door(s) **fully**.

Manual Operating Instructions

In event of power or equipment failure, refer to the Manual Operating Instructions to manually operate the lift. Refer to the Lift Operating Instructions for all normal lift operation procedures (such as loading and unloading passengers). **Follow all Lift Operation Safety Precautions at all times!**

Familiarize yourself with the components necessary to manually operate the lift. The

T-handle release cable releases and engages the lift platform to allow the platform to be manually extended and retracted. The manual back-up pump (hand pump) is used to manually lower and raise the extended platform.

The location of the power pack and release cable varies from vehicle to vehicle (depending on your particular installation).

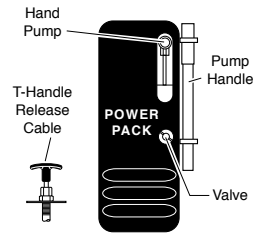

Note: Location of power pack and T-handle varies.

Cable-Activated Platform Manual Release System

Platform Manual Release System: A cable-activated manual release system releases and engages the platform carriage assembly drive chain to allow the platform carriage assembly to be manually moved out (extended) or moved in (retracted) as needed. A T-handle is provided on the release cable for activation of the manual release system (details follow).

After manually moving the platform in or out, it is extremely important that the cable-activated manual release is positively re-engaged to secure (lock) the platform carriage assembly before loading a passenger on the platform or before driving the vehicle.

Failure to manually lock the platform carriage assembly (re-engage the carriage assembly drive chain) after manual deployment,

will allow the platform to roll in or out of housing unhindered during vehicle movement. Failure to lock the platform will also allow the platform to roll in or out of housing unhindered during hand pump raising and lowering procedures.

After manually releasing platform, push manual release T-handle in fully and ensure platform is locked before driving lift vehicle. Uncontrolled and unintentional platform deployment (inadvertent platform ejection) may result in serious bodily injury and/or property damage.

Note: The lift platform must be pushed back into its carriage compartment at least half-way before reverting back to normal (powered) operation. When the lift is fully extended manually, it does not activate the proper



switches for normal operation. Returning (moving) the lift at least half-way in allows for proper switch activation.

Manual Operating Instructions

OUT (TO EXTEND PLATFORM):

1. Pull T-Handle.
2. Turn T-Handle to lock platform in released position.
3. Pull platform out.
4. Turn T-Handle.
5. Push T-Handle in.
6. Turn T-Handle to lock platform in engaged position.

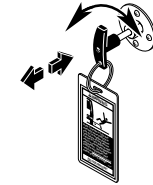

DOWN (TO LOWER PLATFORM):

Using hand pump handle, open hand pump valve (turn counterclockwise). Open 1/2 turn only.

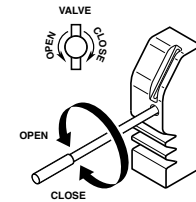

DOWN (TO UNFOLD OUTER BARRIER):

1. Remove hairpin cotter from detent pin.
2. Remove detent pin.
3. Unfold (rotate) barrier down.

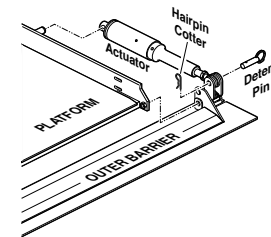

UP (TO FOLD OUTER BARRIER):

1. Fold (rotate) barrier up.
2. Insert detent pin.
3. Insert hairpin cotter in detent pin.

UP (TO RAISE PLATFORM):

- Using hand pump handle:
1. Close hand pump valve (turn clockwise).
 2. Insert handle in pump and stroke.

Note: Close valve before operating electric pump.

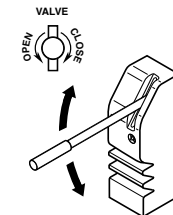

IN (TO STOW PLATFORM):

1. Raise or lower platform to stow level (follow UP or DOWN procedures).
2. Pull T-Handle.
3. Turn T-Handle to lock platform in released position.
4. Push platform in.
5. Turn T-Handle.
6. Push T-Handle in.
7. Turn T-Handle to lock platform in engaged position.

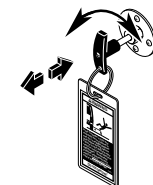

Maintenance and Lubrication

Proper maintenance is necessary to ensure safe, trouble-free operation. Inspecting the lift for any wear, damage or other abnormal conditions should be a part of all transit agencies's daily service program. Simple inspections can detect potential problems.

The maintenance and lubrication procedures specified in the following schedule **must** be performed by a Braun authorized service representative at the scheduled intervals according to the number of cycles. NHTSA NUVL Series lifts are equipped with a cycle counter (digital display built into the electronic control board).

NUVL Series lifts are equipped with hardened pins and self-lubricating bushings to decrease wear, provide smooth operation and extend the service life of the lift.

When servicing the lift at the recommended intervals, inspection and lubrication procedures specified in the previous sections should be repeated. **Clean** the components and the surrounding area **before** applying lubricants. LPS2 General Purpose Penetrating Oil is recommended where Light Oil is called out. Use of improper lubricants can attract dirt or other contaminants which could result in wear or damage to the components. Platform components exposed to contaminants when lowered to the ground may require extra attention.

Lift components requiring grease are lubricated during assembly procedures. When replacing these components, be sure to apply grease during installation procedures. Specified lubricants are available from The Braun Corporation (part numbers below).

All listed inspection, lubrication and maintenance procedures should be repeated at "750 cycle" intervals following the scheduled "4500 Cycles" maintenance. These intervals are a general guideline for scheduling maintenance procedures and will vary according to lift use and conditions. Lifts exposed to severe conditions (weather, environment, contamination, heavy usage, etc.) may require inspection and maintenance procedures to be performed more often than specified.

Maintenance Indicator: The Lift Ready green LED mounted on top of the pump cover will change from green to amber after every 750 cycles. The color change will not affect lift functions, but indicates that it is time to perform specified maintenance and lubrication procedures. Once the lift has been serviced, fully stow the lift. Once stowed, press the CYCLE button on the pump-mounted control board below the LCD screen.

Discontinue lift use immediately if maintenance and lubrication procedures are not properly performed, or if there is any sign of wear, damage or improper operation. Contact your sales representative or call The Braun Corporation at 1-800-THE LIFT®. One of our national Product Support representatives will direct you to an authorized service technician who will inspect your lift.

⚠ WARNING

Maintenance and lubrication procedures must be performed as specified by an authorized service technician. Failure to do so may result in serious bodily injury and/or property damage.

Lubrication Diagram

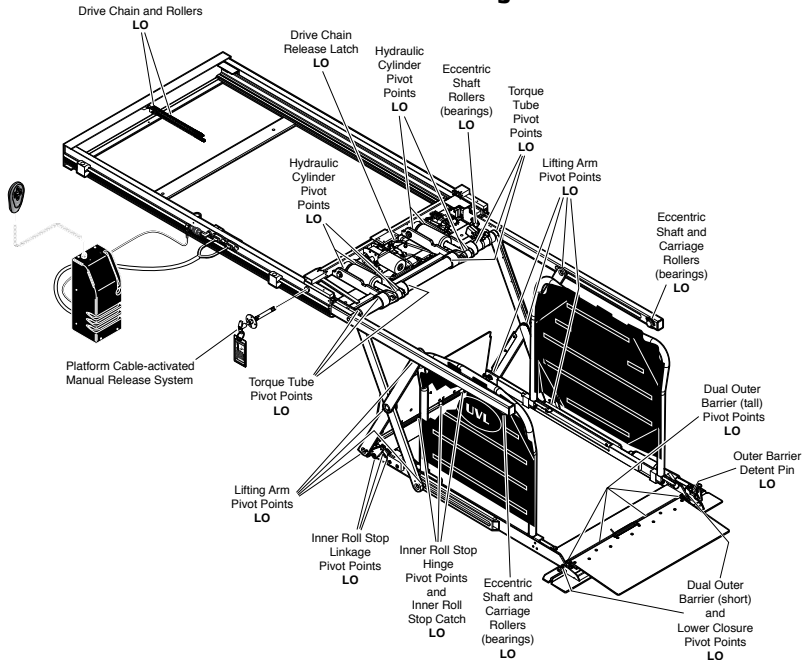

Lubricant	Type	Specified (recommended) Lubricant	Available Amount	Braun Part No.
LO - Light Oil	Light Penetrating Oil (30 weight or equivalent)	LPS2, General Purpose Penetrating Oil	11 oz. Aerosol Can	15807
DE - Door-Ease	Stainless Stick Style (tube)	Door-Ease Stick (tube)	1.68 oz.	15806
LG - Light Grease	Light Grease (Multipurpose)	Lubriplate	14 oz. Can	15805

750 Cycles	Outer barrier and lower closure pivot points (2)	Apply Light Oil - See Lubrication Diagram
	Outer barrier detent pin pivot points (2)	Apply Light Oil - See Lubrication Diagram
	Inner roll stop hinge pivot points	Apply Light Oil - See Lubrication Diagram
	Inner roll stop linkage pivot points	Apply Light Oil - See Lubrication Diagram
	Lifting arm center and platform pivot points (bearings at all points)	Apply Light Oil - See Lubrication Diagram
	Inspect outer barrier and lower closure for proper operation	Correct or replace damaged parts.
	Inspect outer barrier seal and lower closure gasket	Resecure, replace or correct as needed
	Inspect outer barrier detent pin hairpin cotter	Ensure hairpin cotter is present and can be removed and inserted easily. Resecure, replace or correct as needed.
	Inspect lift for wear, damage or any abnormal condition	Correct as needed.
	Inspect lift for rattles	Correct as needed.
1500 Cycles	Check drive chain tension.	Pull out and lock manual release cable. Adjust chain tension as needed. See Drive Chain Adjustment.
	Inspect inner roll stop (bridge plate) and linkage for:	Resecure, replace or correct as needed. See Bridge Plate Adjustment Instructions.
	• Proper operation. Rollstop should rest solidly on floor providing smooth transition.	
	• Positive securement	
	• Wear or damage	
	Check carriage ride height in housing	Adjust as needed. See Carriage Ride Height Adjustment.
	Check stow height/lifting arm alignment	Lifting arms should be horizontal, aligned with each other and aligned with carriage. Adjust as needed. See Switch Adjustment (Stow Switch).
	Inspect wiring harnesses for securement, wear or other damage	Resecure, replace or correct as needed
	Check lower pan securement	Resecure, replace damaged parts or correct as needed.
	Torque tube pivot bearings (4 places)	Apply Light Oil - See Lubrication Diagram
Carriage and eccentric shaft rollers (bearings)	Apply Light Oil - See Lubrication Diagram	

Braun Corporation FMVSS No. 403 Quick Reference Installation Sheet 32553

Maintenance and Lubrication

1500 Cycles	Hydraulic cylinder pivot points (4 per cylinder)	Apply Light Oil - See Lubrication Diagram
	Drive chain and chain rollers	Apply Light Oil - See Lubrication Diagram
	Drive chain release latch mechanism	Apply Light Oil - See Lubrication Diagram
	Deploy lift, remove lower pan and blow out housing. Blow off platform also.	Use compressor and nozzle to remove all debris from housing. NUVL603 Note: Clean lower pan slot and apply Antisize to slot before reinstalling pan.
	Deploy lift, remove lower pan and clean housing tracks	Use clean cloth and solvent to clean tracks. NUVL603 Note: Clean lower pan slot and apply Antisize to slot before reinstalling pan.
	Check drive chain tensioner, jam nuts and connecting link for securement and/or misalignment.	Correct or replace damaged parts and/or relubricate. See Drive Chain Adjustment.
	Inspect drive chain release latch mechanism for proper operation, positive securement, wear or other damage	Correct or replace damaged parts and/or relubricate.
	Inspect platform cable-activated manual release system (T-handle/cable assembly and carriage movement)	Ensure T-handle release and cable assembly operate properly (see Manual Operation). Ensure carriage can be manually extended and retracted freely.
	Inspect microswitches for securement and proper adjustment	Resecure, replace or adjust as needed. See Switch Adjustment.
	Inspect carriage, lifting arm and eccentric shaft rollers (bearings) for wear or damage, positive securement and proper operation	Correct, replace damaged parts and/or relubricate.
	Inspect external snap rings (e-clips): • Carriage roller bearings (4) • Lower lifting arm pins (4) • Eccentric shaft track roller bearing (1)	Resecure, replace or correct as needed.
	Inspect lower lifting arm pins for wear or damage, positive securement and proper adjustment	Resecure, replace damaged parts, lubricate or correct as needed. See Switch Adjustment (Stow Switch)
	Inspect eccentric shaft pins, bearing mounting screw, washers and securement hardware for wear or damage, positive securement and proper operation	Resecure, replace damaged parts, lubricate or correct as needed. See Carriage Ride Height Adjustment.

4500 Cycles	Hydraulic Fluid (Pump) - Check level. Note: Fluid should be changed if there is visible contamination. Inspect the hydraulic system (cylinder, hoses, fittings, seals, etc.) for leaks if fluid level is low.	Use 5606 aviation fluid only (part 87010R-MILL). Check fluid level with platform lowered fully . Fill to within 1"-1/2" of the bottom of the fill tube (neck).
	Inspect lifting arm bushings and pivot pins for visible wear or damage	Replace if needed.
	Inspect outer barrier pivot pin mounting bolts (2)	Tighten or replace if needed
	Mounting	Check to see that the lift is securely anchored to the vehicle and there are no loose bolts, broken welds, or stress fractures.
	Decals and Antiskid	Replace decals if worn, missing or illegible. Replace antiskid if worn or missing.

Consecutive 750 Cycle Intervals	Repeat all previously listed inspection, lubrication and maintenance procedures at 750 cycle intervals.
----------------------------------------	----------------------------------------------------------------------------------------------------------------

Adjustments and Calibration

Adjustment Procedures

Lift Out Switch: The Lift Out Switch stops inward travel of the carriage/platform during Stow function (activated by the housing-mounted Lift Out Cam). Move cam in to increase inward travel. Move cam out to decrease inward travel.

Full Out Switch: The Full Out Switch stops outward travel of the carriage/platform during Deploy (Up/Down) functions (activated by the housing-mounted Full Out Cam). Move cam in to decrease outward travel. Move cam out to increase outward travel. Carriage rollers must be inside housing a minimum 1/2". The platform will not raise or lower until this switch is activated.

Floor Level Switch: Detailed on opposite side.

Stow Switch: The Stow Switch controls the height of the carriage/platform before it moves inward during the Stow function (activated by the torque tube-mounted Stow Cam). Rotate the cam in to decrease platform height. Rotate the cam out to increase platform height. Adjust cam so lifting arms are aligned. View the platform position in the housing.

Barrier Down Switch: This platform-mounted switch prohibits the platform from raising unless the outer barrier is in the full up position. The Up function is prohibited if the outer barrier detent pin is not fully engaged also.

Drive Chain Adjustment

In event the drive chain sags 1/2" or more, adjust tension as detailed. Tighten to eliminate visible sag but do not overtighten.

1. Remove bottom pan.
2. Pull the manual release cable and lock.
3. Remove adjustment bolt (tensioner) access cover.
4. Loosen inside jam nut. Secure tensioner and tighten outside jam nut. Tighten to eliminate visible chain sag but do not overtighten.
5. Lock jam nuts together making sure the tensioner roller is horizontal. Release and push the manual cable in fully. Ensure platform is locked by moving the platform in and out until chain release assembly engages chain.

Calibration Procedures

Platform Sense Calibration

1. There must be **no weight on platform**.
2. Press handheld pendant UP switch to raise platform a minimum 3" above stow level.
3. Press and hold control board SW1 button. While pressing the SW1 button, press and hold the handheld pendant STOW switch (button). The platform will lower to stow level (begin stow function), and then start to raise. Release SW1 button immediately when platform starts to raise from stow level.

Ground Sense Calibration

1. Press handheld pendant DOWN switch to lower platform fully to ground level.
2. While continuing to press the pendant DOWN switch, press and then release control board SW2 button.
3. Release the pendant DOWN switch.

Outer Barrier Occupied Calibration

1. Press handheld pendant DOWN switch to lower platform fully to ground level.
2. Once outer barrier is fully unfolded (ramp position), release the pendant DOWN switch.
3. Press and hold the control board SW2 button. While holding SW2 button, press handheld pendant UP switch to raise the outer barrier. Be sure to release SW2 button when outer barrier reaches approximately half full up (vertical) position.

Carriage Ride Height Adjustment

The carriage horizontal arms move (roll) in and out of the housing tracks on roller bearings. Following installation or extensive lift operation, clearance between horizontal arms and tracks may diminish. The eccentric shaft mounting plate allows height adjustment.

Remove eccentric plate mounting screw. Using screwdriver or small rod, rotate the shaft clockwise to increase carriage height. Rotate the shaft counterclockwise to decrease carriage height. Reinstall mounting screw in nearest retainer hole. Adjust left and right side eccentric shafts (screw positions may vary from side to side). Adjust height such that horizontal arms do not contact top or bottom of tracks (align center).